

93	Elastic Ring	1
94	Nylon Lock Nut, M10	2
95	Phillips Head Screw, ST4.2x6mm	6
96	Phillips Head Screw, M4x45mm	1
97	Hex Nut, M4	1
98	Pull Pin	1
99	Socket Head Cap Screw, M6x16mm	14
100	Phillips Head Screw, M6x30mm	2
101	Phillips Head Screw, M6x10mm	7
102	Screwdriver	1
103	Allen Wrench, 6mm	1
104	Wrench	1
105	Hex Nut, M6	2
106	PU Spacer	2
107	Plug	1
108	Bearing, 6001RS	1
109	Balance Weight	3
110	Bearing Bushing	1
111	Socket Head Cap Screw, M4x12mm	3
112	Washer, $\varnothing 12 \times \varnothing 3.5 \times 1$ mm	2
113	Phillips Head Screw, ST3.0x12mm	2
114	Magnet	1
115	Warning Label	1
116	Stopper Bumper	2
117	Socket Head Cap Screw, M8x20mm	2
118	Stopper Bracket	1
119	Manual	1
120	EVA Single Glue	2

PB EXTREME ROWER

OWNER'S MANUAL

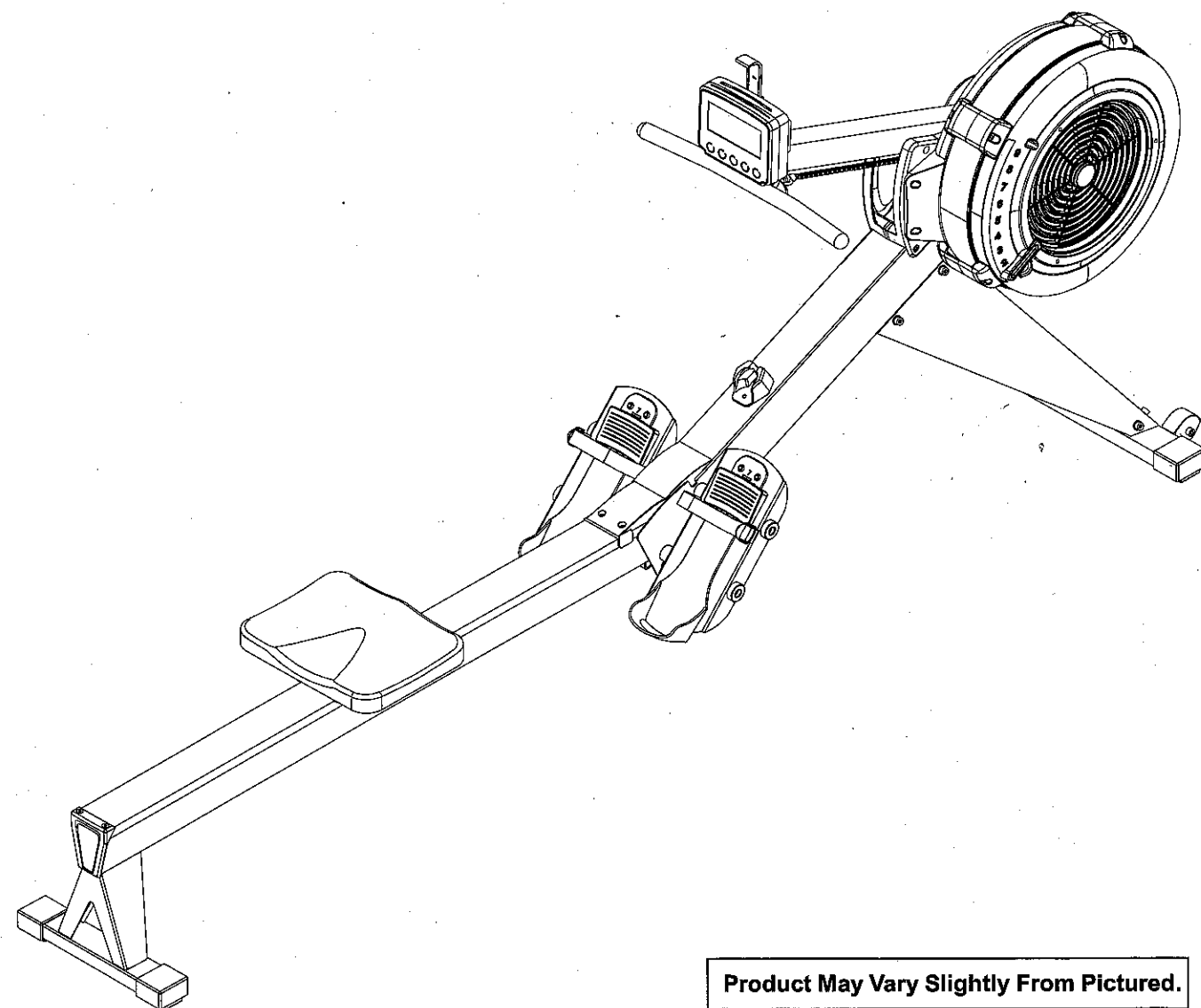

Product May Vary Slightly From Pictured.

Safety Instructions	2	Storage.....	19
Before You Begin	3	Product Parts Drawing	20
Equipment Warning, Warning Labels.....	4	Parts List.....	21
Hardware Identification Chart	5		
Assembly Instructions	6		
Computer Instructions	11		
Operational Instructions	16		
Maintenance	17		

SAFETY INSTRUCTIONS

1. To reduce the risk of serious injury, read the following Safety Instructions before using the **ROWER**.
2. Save these instructions and ensure that other exercisers read this manual prior to using the **ROWER** for the first time.
3. Read all warnings and cautions posted on the **ROWER**.
4. The **ROWER** should only be used after a thorough review of the Owner's Manual. Make sure that it is properly assembled and tightened before use.
5. We recommend that two people be available for assembly of this product.
6. Keep children away from the **ROWER**. Do not allow children to use or play on the **ROWER**. Keep children and pets away from the **ROWER** when it is in use.
7. It is recommended that you place this exercise equipment on an equipment mat.
8. Set up and operate the **ROWER** on a solid level surface. Do not position the **ROWER** on loose rugs or uneven surfaces.
9. Make sure that adequate space is available for access to and around the **ROWER**.
10. Before using, inspect the **ROWER** for worn or loose components, and securely tighten or replace any worn or loose components prior to use.
11. Before using, check the condition of the CHAIN(36). Replace the CHAIN(36) if it is cracked or broken.
12. Consult a physician prior to commencing an exercise program and follow his/her recommendations in developing your fitness program. If at any time during exercise you feel faint, dizzy, or experience pain, stop and consult your physician. Failure to follow all warnings and instructions could result in serious injury or death.
13. Always choose the workout which best fits your physical strength and flexibility level. Know your limits and train within them. Always use common sense when exercising.
14. Do not wear loose or dangling clothing while using the **ROWER**.
15. Never exercise in bare feet or socks; always wear proper footwear such as running, walking, or cross training shoes that fit well, provide foot support, and feature non-skid rubber soles.
16. Be careful to maintain your balance while using, mounting, dismounting, or assembling the **ROWER**, loss of balance may result in a fall and bodily injury.
17. Do not use the SEAT(51) to move the **ROWER**. The SEAT(51) will move and the SEAT CARRIAGE(10) may pinch your hand or fingers. When assembling or separating the unit, keep all children away and make sure your hands are clear of any pinch point.
18. The **ROWER** should not be used by persons weighing over 297 lbs /135 kgs.
19. The **ROWER** should be used by only one person at a time.

BEFORE YOU BEGIN

Thank you for choosing the **ROWER**. We take great pride in producing this quality product and hope it will provide many hours of quality exercise to make you feel better, look better, and enjoy life to its fullest.

It's a proven fact that a regular exercise program can improve your physical and mental health. Too often, our busy lifestyles limit our time and opportunity to exercise. The **ROWER** provides a

convenient and simple method to begin your journey of getting your body in shape and achieving a happier and healthier lifestyle.

Before reading further, please review the drawing below and familiarize yourself with the parts that are labeled.

Read this manual carefully before using the **ROWER**.

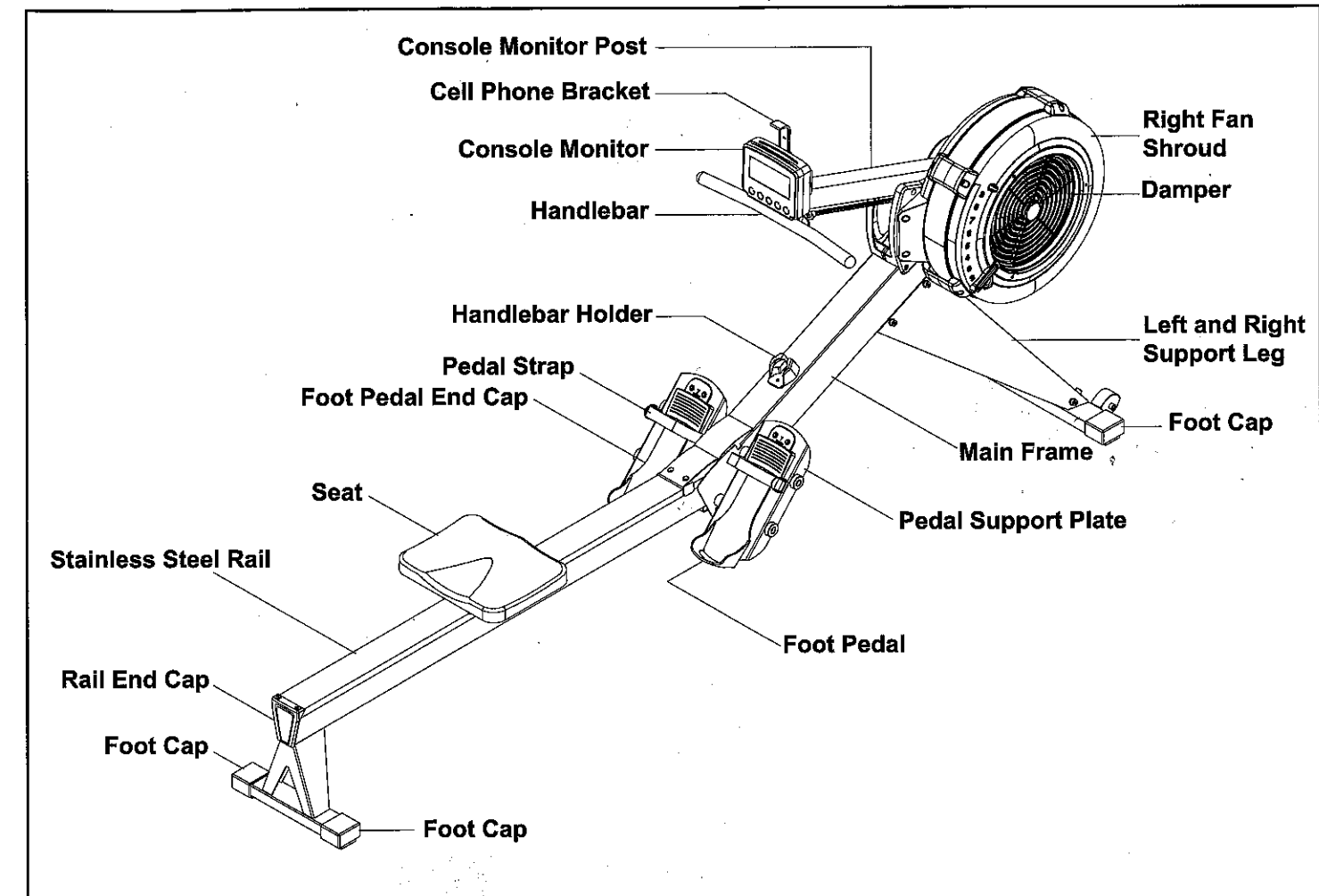

THE FOLLOWING TOOLS ARE INCLUDED FOR ASSEMBLY :



Allen Wrench (6mm)



Screwdriver



Wrench

EQUIPMENT WARNING, WARNING LABELS

This chart is provided to help identify the warning, caution, and notice labels on the **ROWER**. Please take a moment to familiarize yourself with all of the warning, caution, and notice labels.

Label is larger than actual size

C1 WARNING LABEL

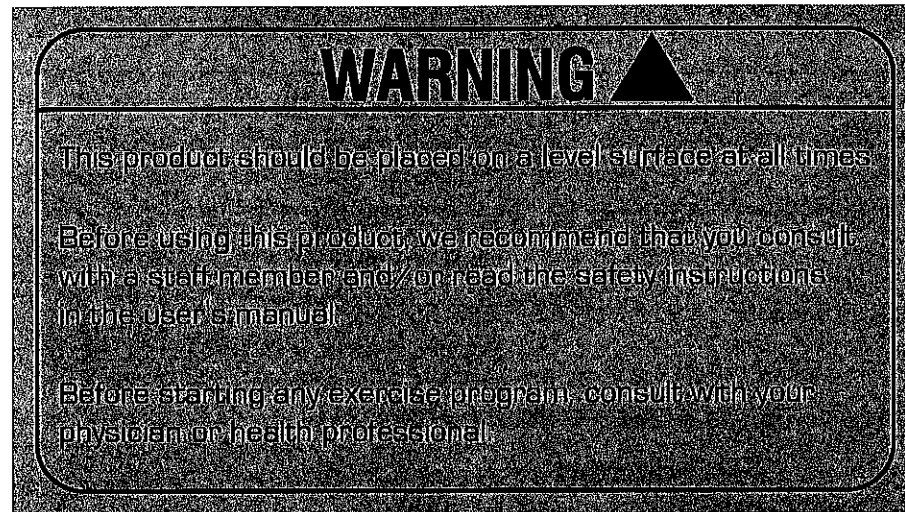



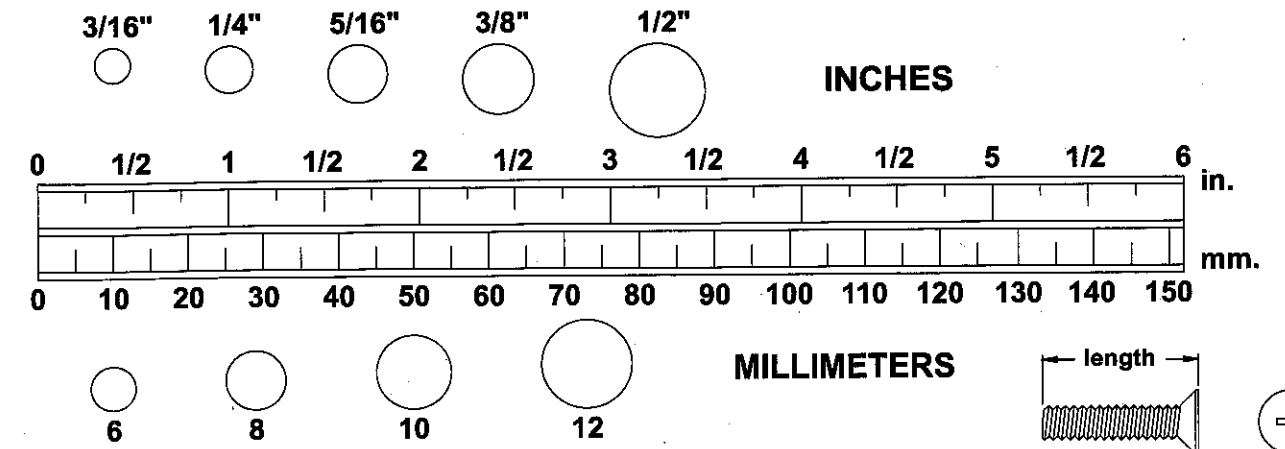

HARDWARE IDENTIFICATION CHART

This chart is provided to help identify the fasteners used in the assembly process. Place the washers or the ends of the bolts or screws on the circles to check for the correct diameter. Use the small scale to check the length of the bolts and screws.

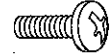
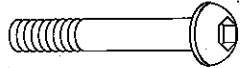

NOTICE: The length of all bolts and screws, except those with flat heads, is measured from below the head to the end of the bolt or screw. Flat head bolts and screws are measured from the top of the head to the end of the bolt or screw.

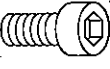
After unpacking the unit, open the hardware bag and make sure that you have all the following fasteners. Some fasteners may be already attached to the parts.

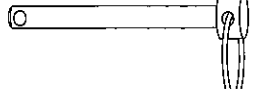
	Part Number and Description	Qty
	72 Phillips Head Screw, M6x10mm	2
	78 Button Head Cap Screw, M8x75mm	1
	79 Flat Washer, M8	1
	80 Nylon Lock Nut, M8	1
	81 Socket Head Cap Screw, M8x12mm	8
	84 Socket Head Cap Screw, M8x160mm	4
	9 Foot Pedal End Cap	4
	98 Pull Pin	1

ASSEMBLY INSTRUCTIONS

STEP 1

First, take out the packing materials **Styrofoam (A)** and **Styrofoam (B)**. Then flip them over so the sides with carved letter are facing up. Take the **Main Frame (1)** out from the carton and put it on both **Styrofoam (A & B)** as picture shown. The **Right and Left Fan Shrouds (43 & 44)** should be placed in the groove of **Styrofoam (B)**.

NOTE: Fan Shrouds will be easily damaged if the whole product is placed on the ground directly during the assembly.

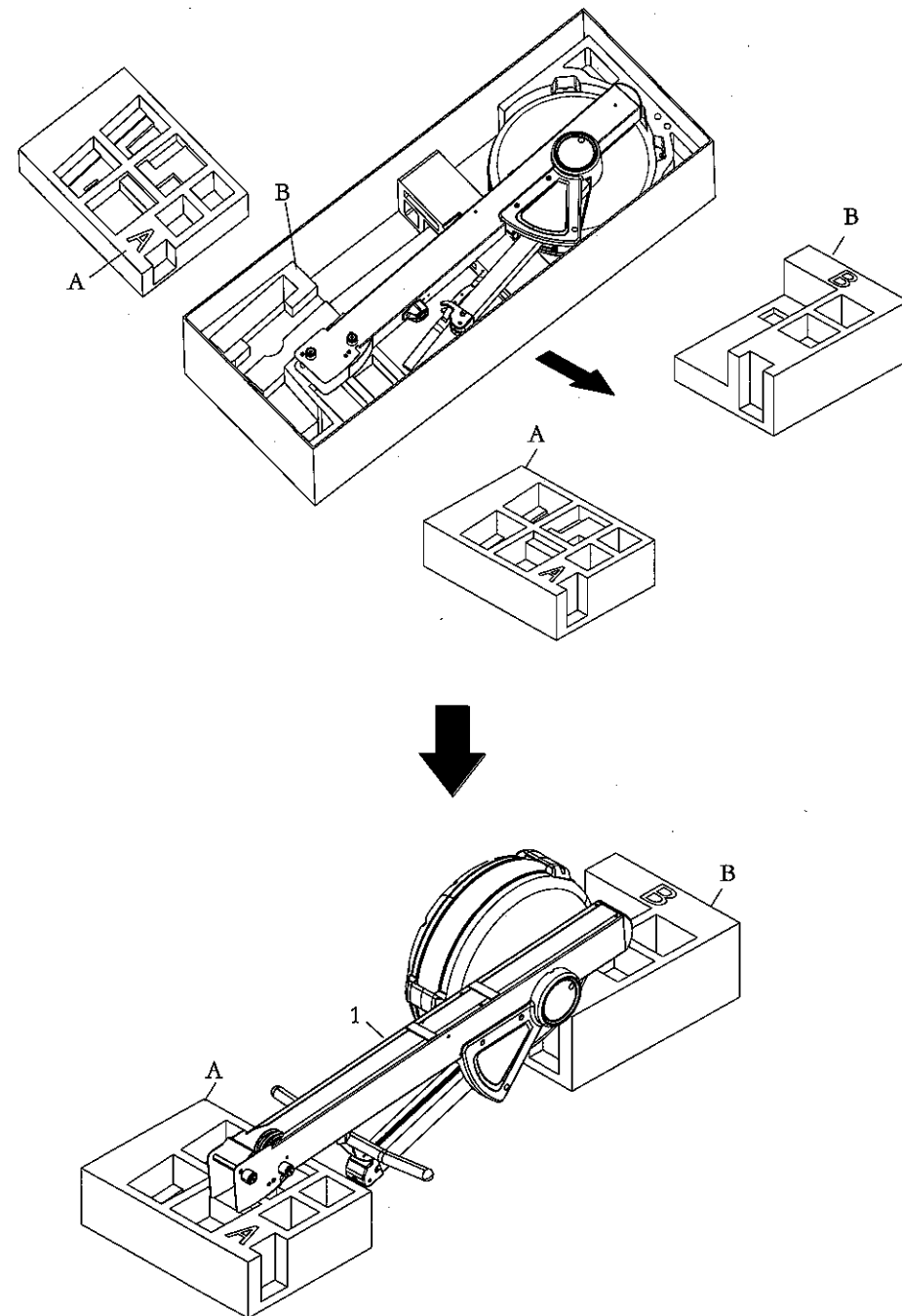

6

STEP 2

Turn the main assembly of the **ROWER** upside down and place it in the packing material **Styrofoam (A & B)** to avoid damage of housing.

Attach **Left and Right Support Legs (7 & 8)** to the **Main Frame (1)** using: 4 PCs of **M8x12mm Socket Head Cap Screw (81)** and **M8 Flat Washer (79)**.

STEP 3

Attach the **Front Stabilizer (4)** to **Left and Right Support Legs (7 & 8)** using: 4 PCs of **M8x12mm Socket Head Cap Screw (81)** and **M8 Flat Washer (79)**. Then tighten all bolts.

NOTE: Fully tighten bolts at end of above steps

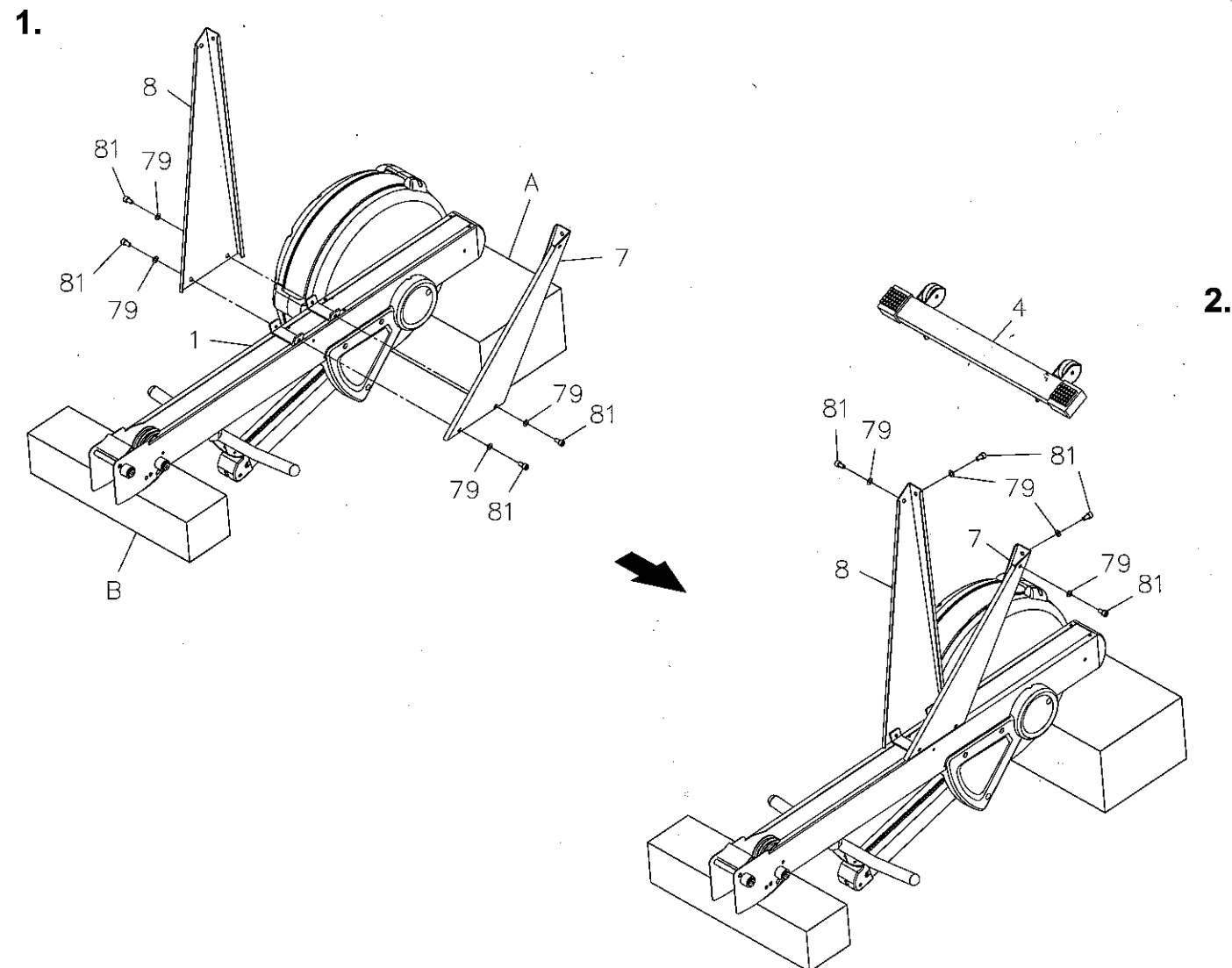

7

STEP 4

Lift up the **Main Frame (1)** and **Rail Frame (2)** to insert the **Rail Frame (2)** into the **Main Frame (1)**. Make the **Shaft (24)** on the **Main Frame (1)** fit into the gap in the **Rail Frame (2)**. Then put the **Main Frame (1)** and **Rail Frame (2)** down.

STEP 5

Insert the **Pull Pin (98)** into the **Main Frame (1)** and **Rail Frame (2)**. Attach **Console Monitor Post (6)** to the **Side Covers (57 & 58)** using: 1 PC of **M6X10 Phillips Head Screw (72)**.

NOTE: Fully tighten bolts at end of above steps.

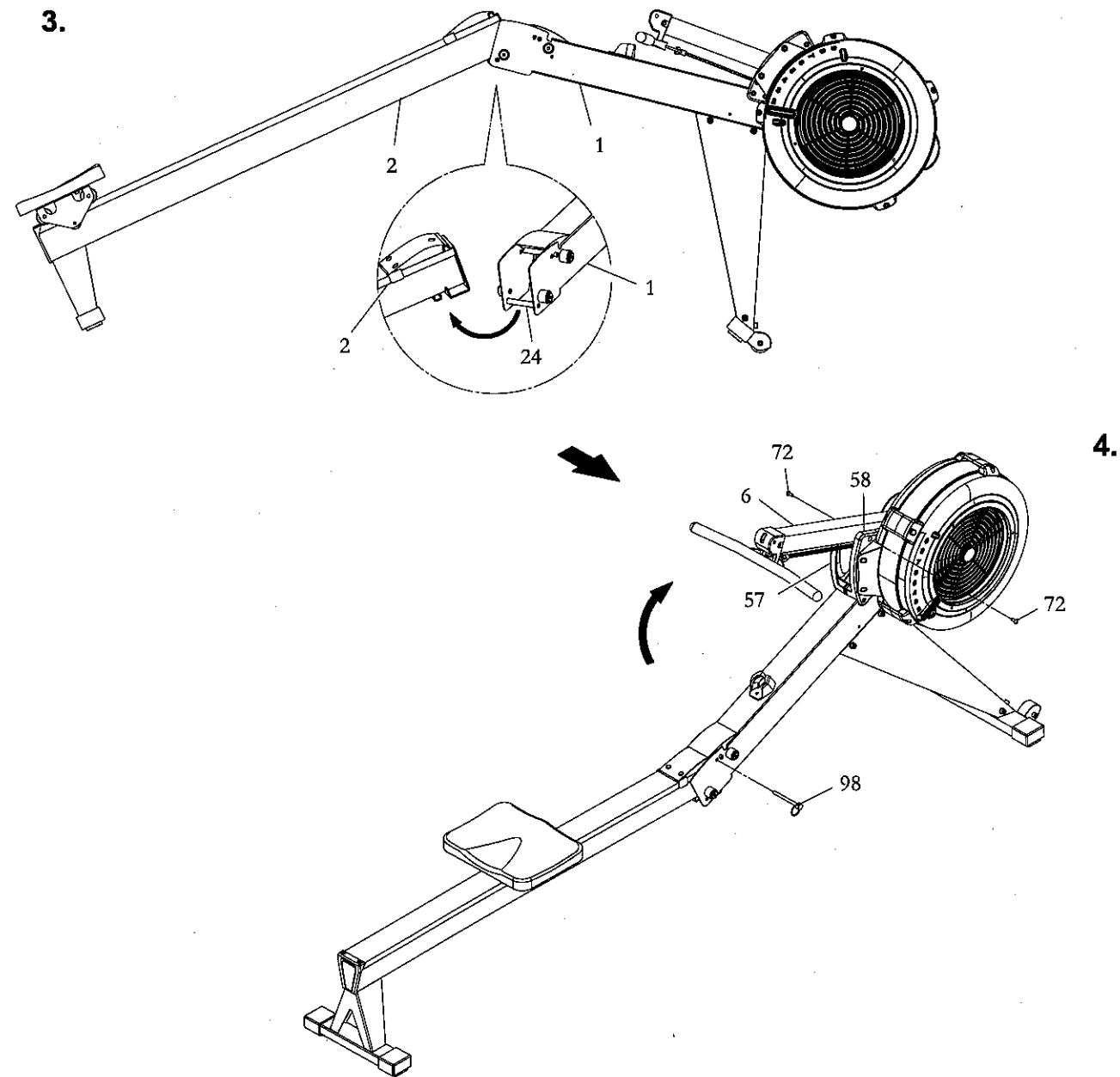

STEP 6

Attach **Pedal Support Plates (5)** to the **Main Frame (1)** using: **M8X160mm Socket Head Cap Screw (84)** and **Foot Pedal End Cap (9)**.

NOTE: Fully tighten bolts at end of this step.

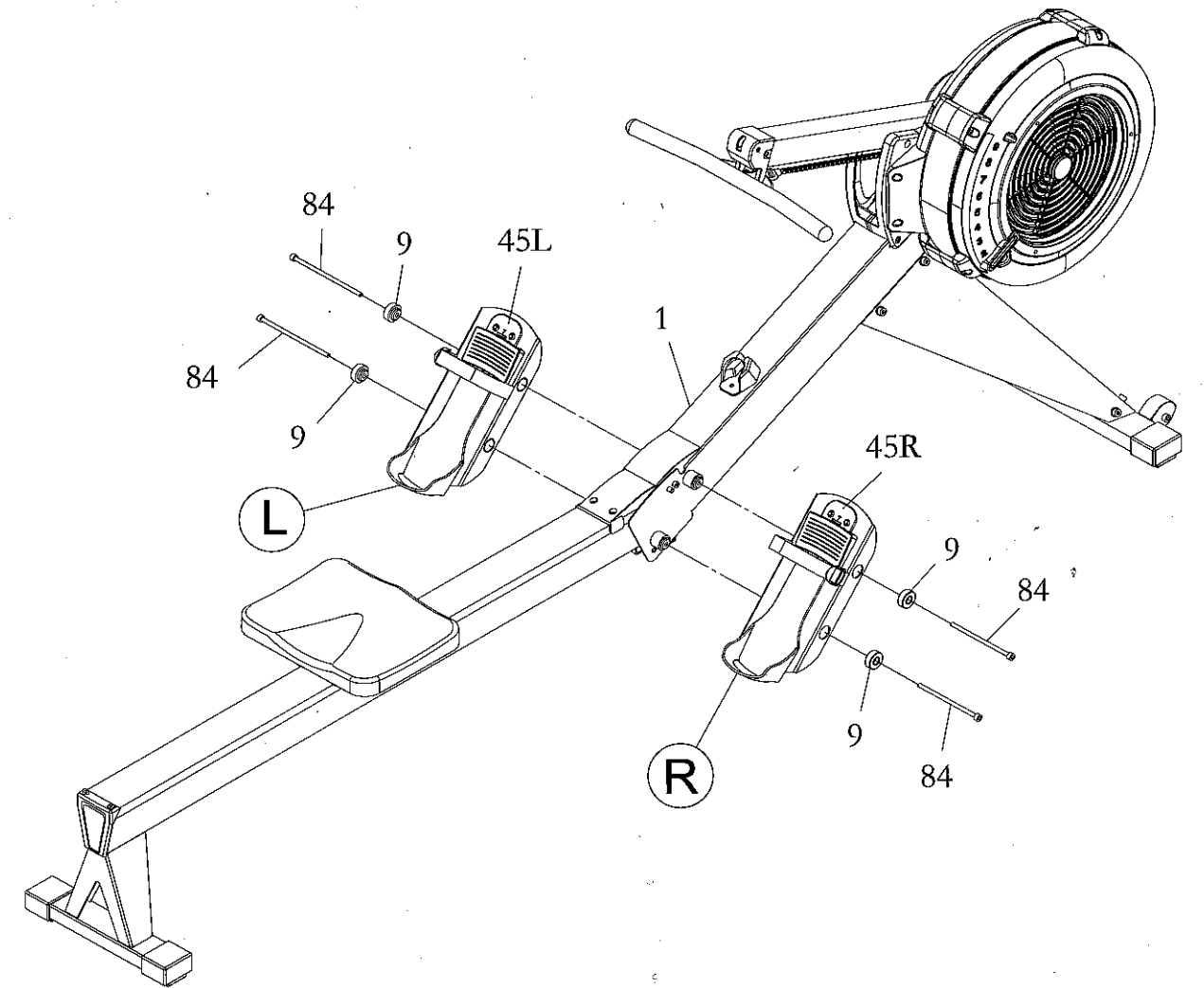

STEP 7

Attach **Cell Phone Bracket (20)** to the **Console Monitor (19)** using **Rubber Band (21)**.

STEP 8

Attach the **Console Monitor (19)** to the **Console Mounting Bracket (69)** using: 1 PC of **M8X75mm Button Head Cap Screw (78)**, **M8 Flat Washer (79)**, and **M8 Nylon Lock Nut (80)**.

STEP 9

Connect **Sensor Cable (23)** into the back of the **Console Monitor (19a)**.

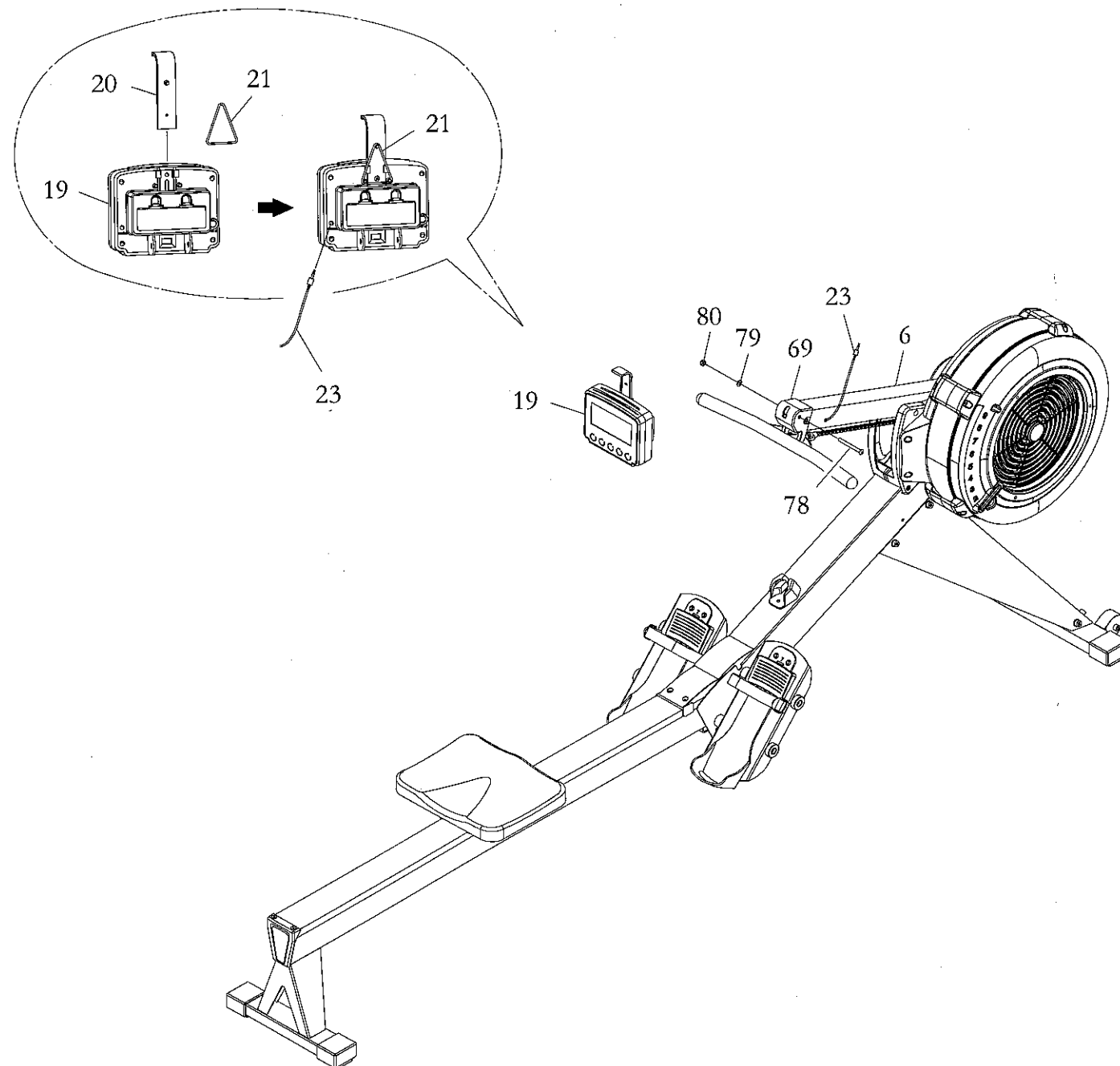

COMPUTER INSTRUCTIONS

Your **ROWER** utilizes an air fan system to create resistance for your workout. We recommend that you use this computer console to vary your workout from session to session and note your progress toward your fitness goals. When used regularly in this way, the computer console can become an important source of motivation and interest which will help keep you on track.

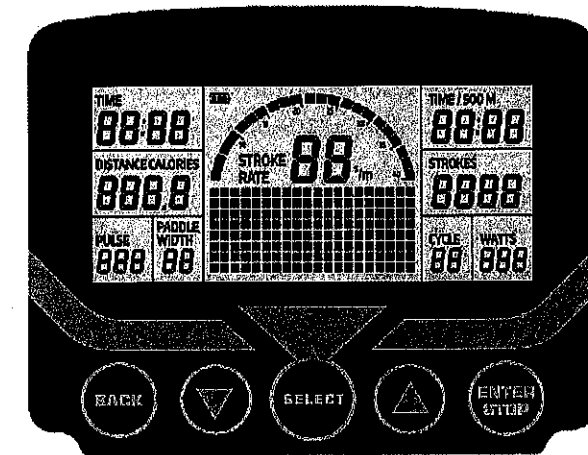

INITIAL SETUP

POWER ON:

- Move the handlebar to start exercising in Quick start program or press any button to go into IDLE mode.

POWER OFF:

- In IDLE mode, automatically shuts off after 20 seconds of inactivity.
- When running an Interval Program, automatically shuts off after 2 minutes of inactivity.
- In all other programs, automatically shuts off after 30 seconds of inactivity.

METRIC & STANDARD UNIT:

- The initial factory setting is in "KM". To toggle between Miles and Kilometers, press and hold "UP" and "DOWN" buttons when console in IDLE mode, it will display flashing "KM" & "MILE". Press "UP" or "DOWN" arrows to select "KM" or "MILE" and then press "ENTER" to confirm.

BATTERY INSTALLATION:

- Console operates on 2 Size C batteries. The battery compartment is on the back of the console. Battery is included.
- When there's no batteries installed, console can still work in Quick start program.

FUNCTION BUTTONS

SELECT BUTTON:

- In IDLE mode, press and release **SELECT** to cycle through each program option. Stop on the program of your choosing. You can preset target values for DISTANCE, TIME, and CALORIES, GAME, or select an Interval Program of 20/10, 10/20, or 10/10.

NOTE: Default exercising mode is Quick start program.

▲ (UP BUTTON):

- Press to increase the preset values. Press the button and hold it down, the presetting value will go faster, release the button to stop.

▼ (DOWN BUTTON):

- Press to decrease the preset values. Press the button and hold it down, the presetting value will go faster, release the button to stop.

BACK BUTTON:

- When selecting the programs, press the button to return to the previous program.
- When you finish a running program, press the button to jump into the IDEL mode.

ENTER/STOP BUTTON:

- When selecting the programs and presetting target values, press the button to confirm.
- Press the button and hold it down for three seconds to reset all functions to zero and restart the computer.
- During exercise, when back light is turned off, the first pressing of this button will turn on the back light. When the back light is still lit, press the button a second time to pause the counting of all function values. Press the button a third time to restart the workout and continue of the counting of all function values.

CONSOLE DISPLAY

STROKE RATE:

- Display the current stroke per minute during exercise.
- The lightened up semi-circle equals to the stroke rate that displayed in numbers. The more grids it shows, the higher your stroke rate is.

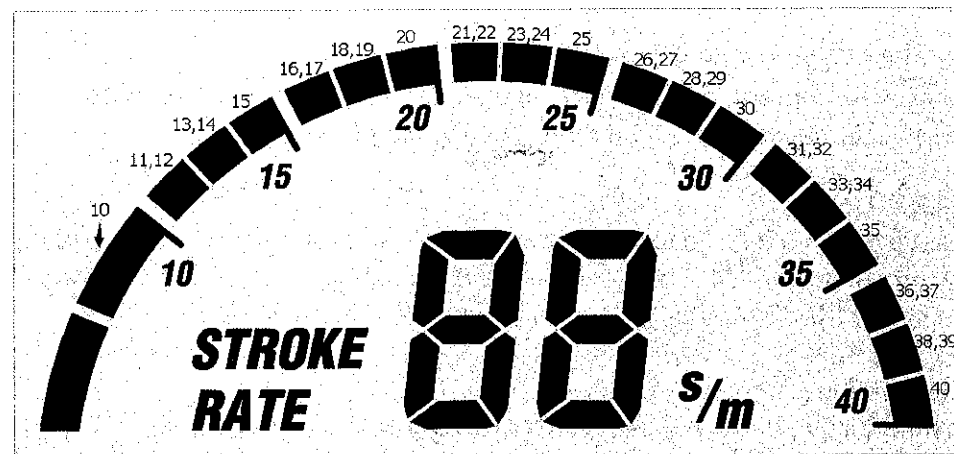

STROKE:

- Display the total number of strokes during exercise.

TIME & TIME/500m AVG:

- Display range: 00:00 ~ 99:59 minutes.
- The workout time is accumulated when under any workout mode.
- Display flashing "00:00" for presetting the TIME (countdown) program. Time can be set from 1:00 to 99:00 minutes.
- Time cannot be saved under 10/10 INTERVAL program. Setting range is 10 ~ 99.
- The time/500m is the average time per hour for reaching distance of 500 meters.

DISTANCE:

- Display range: 0 ~ 9999 meters. It's accumulated in cycle mode that numbers go back to 0 if the distance exceeds 9999 meters.
- The workout distance is accumulated when under any workout mode.
- Display flashing "500" for presetting DISTANCE (countdown) program. The target distance value can be set from 500 to 9999 meters.
- The distance/30min is the estimated distance for 30 minutes with the current stroke rate.

CALORIES:

- Display range: 0 ~ 999 cal.
- Display flashing "100" for presetting CALORIES (countdown) program. The target calories value can be set from 10 to 999 cal.

PULSE:

- Display the heart rate from 40 to 220 beats per minute during exercise. To use this function, the user must wear Heart Rate Chest Strap.

PADDLE WIDTH:

- Display range: 0 ~ 99 meters (or 0 ~ 304 feet).
- Display the distance each stroke can reach.

CYCLE:

- Display only in INTERVAL program.
- Display flashing "8" for presetting the target rounds of exercise in INTERVAL program. The target cycle value can be set from 1 to 99 rounds.

WATTS:

- Display range: 0 ~ 999 watts.
- Display the amount of power generated at any moment during the workout.

LOW BATTERY REMINDER:

- Display battery symbol only when the battery is low.

PROGRAMS

The Console Monitor has eight programs: QUICK START, TIME (countdown), DISTANCE (countdown), CALORIES (countdown), GAME, and INTERVAL PROGRAMS of 20/10, 10/20, & 10/10.

Press "Select" to change workout program according to the following sequence: Quick Start → Distance → Time → Calories → Game → 20/10 Interval → 10/20 Interval → 10/10 User Setting Interval

1. QUICK START PROGRAM

- To Quick Start the program, you can pull on the Handlebar(3) to start. All function values for the console will count up.
- Press "STOP" button once to temporarily stop counting all values (Pause function). Pull the Handlebar (3) again to continue the counting. Long press "STOP" button to delete all counting data.

- For Quick Start and all three countdown programs, press **"SELECT"** button to choose the data displayed in the same display window, including Time & Time/500m AVG.
- For the other seven programs, press **"BACK"** button to enter IDLE mode. Or press and hold **"ENTER/STOP"** button for over 3 seconds to re-start the console. Use **"SELECT"** button to toggle between programs. Use **"UP"** and **"DOWN"** buttons to adjust the value and press **"ENTER/STOP"** to confirm.

2. DISTANCE (Countdown) PROGRAM

- During the workout, the **"DISTANCE"** program will count down from preset value.
- The program will start once the user pulls the Handlebar(3). When the program is finished, the monitor will show **"WINNER"** with an audible alarm. Press the **"BACK"** button to go to the IDLE mode.

3. TIME (Countdown) PROGRAM

- During the workout, the **"TIME"** program will count down from preset value. The program will start once the user pulls the Handlebar(3). When the program is finished, the monitor will end with an audible alarm. Press **"BACK"** button to go to the IDLE mode.

4. CALORIES (Countdown) PROGRAM

- During the workout, the **"CALORIES"** program will count down from preset value. The program will start once the user pulls the Handlebar(3). When the program is finished, the monitor will show **"END"** with an audible alarm. Press **"BACK"** button to go to the IDLE mode.

5. GAME PROGRAM

- When the **"GAME"** program is selected, the program will start once the user pulls the Handlebar. There is no presetting value to be entered. When the program is finished, the monitor will show your score with an audible alarm. Press the **"BACK"** button to go to the IDLE mode.

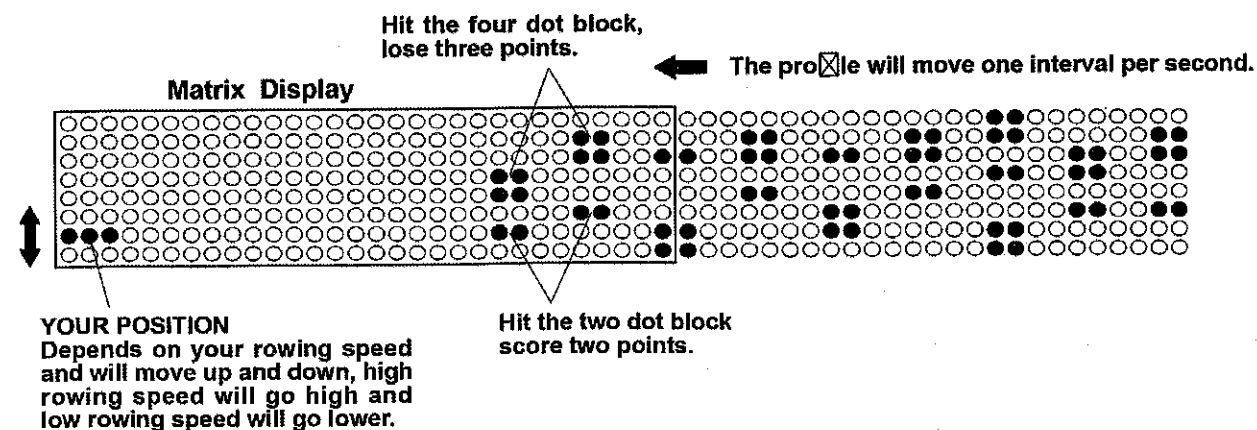

6. 20/10 INTERVAL PROGRAM

- When it is in the **"20/10 INTERVAL"** program, the console monitor will display flashing "8" for presetting value of cycle. "20" is 20 seconds for exercising, and "10" is 10 seconds for resting. Then user can use **"UP"** and **"DOWN"** buttons to input the value from 1 to 99. The user will workout for 20 seconds and then rest for 10 seconds. When the program is finished, the monitor will end with an audible alarm. Press the **"BACK"** button to go to the IDLE mode.

7. 10/20 INTERVAL PROGRAM

- When it is in the **"10/20 INTERVAL"** program, the console monitor will display flashing "8" for presetting value of cycle. Then user can use **"UP"** and **"DOWN"** buttons to input the value from 1 to 99. User will workout for 10 seconds and then rest for 20 seconds. The program will start once the user pulls the Handlebar(3). When the program is finished, the monitor will end with an audible alarm. Press the **"BACK"** button to go to the IDLE mode.

8. 10/10 INTERVAL PROGRAM

- When it is in the **"10/10 INTERVAL"** program, the console monitor will display flashing "8" for presetting value of cycle. Then user can use **"UP"** and **"DOWN"** buttons to input the value from 1 to 99 for number of cycle, workout time, and rest time. The program will start once the user pulls the Handlebar(3). When the program is finished, the monitor will end with an audible alarm. Press the **"BACK"** button to go to the IDLE mode.

OPERATIONAL INSTRUCTIONS

LOAD ADJUSTMENT

There is a **Damper (42)** built into the **Right Fan Shroud (43)**. Move the **Indicator** in the **Damper (42)** to point to the numbers on the **Right Fan Shroud (43)** to adjust the load. There are settings from 1 to 9. Setting #1 will provide the lowest resistance. Setting #9 will provide the highest resistance.

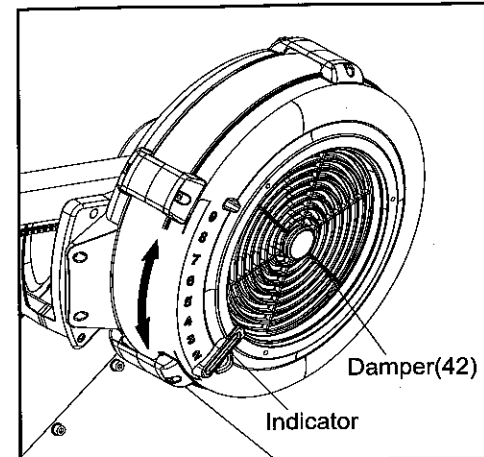

HANDLEBAR POSITION

The **Handlebar (3)** can be placed on the hook in the **Console Monitor Post (6)**, refer to illustration A. Or, you can place the **Handlebar (3)** on the **Handlebar Holder (52)** as shown in illustration B.

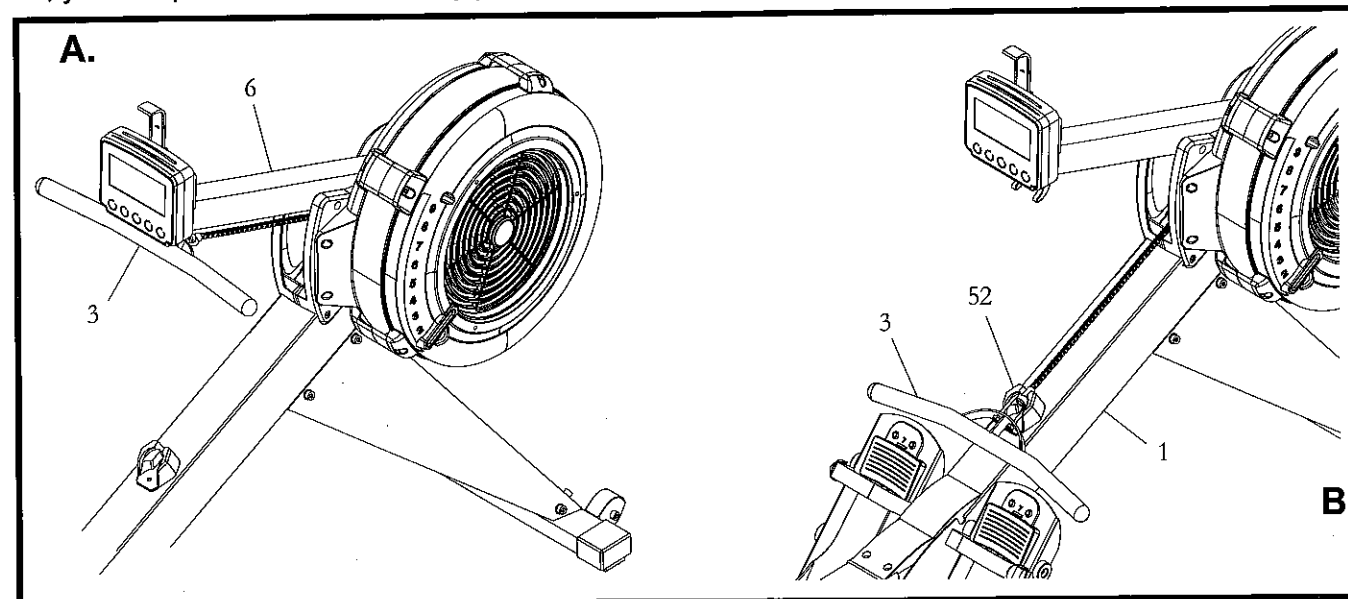

PEDAL CAP ADJUSTMENT

The position of the **Foot Pedal (45)** can be adjusted. Refer to the illustration. Pull the **Foot Pedal (45)** out from the two bulges in the **Pedal Support Plate (5)**, then lower or raise the **Foot Pedal (45)** to the desired position. Lock the **Foot Pedal (45)** in position by pressing the adjustment holes of the desired position onto the two bulges.

Refer to the numbers on the **Foot Pedal (45)** to make sure that **Foot Pedal (45)** are adjusted on the same position on both sides.

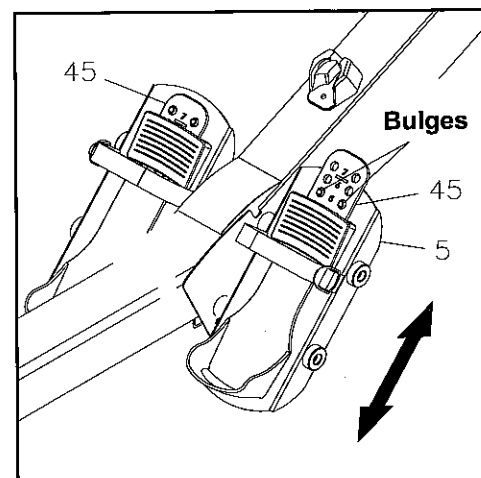

OPERATIONAL INSTRUCTIONS

USING THE CELL PHONE BRACKET

The **Cell Phone Bracket (20)** can move up and down. Move up the **Cell Phone Bracket (20)**, then slide the **Cell Phone** into the gap between the **Cell Phone Bracket (20)** and the **Console Monitor (19)**. Move down the **Cell Phone Bracket (20)** to clip the **Cell Phone** in position.

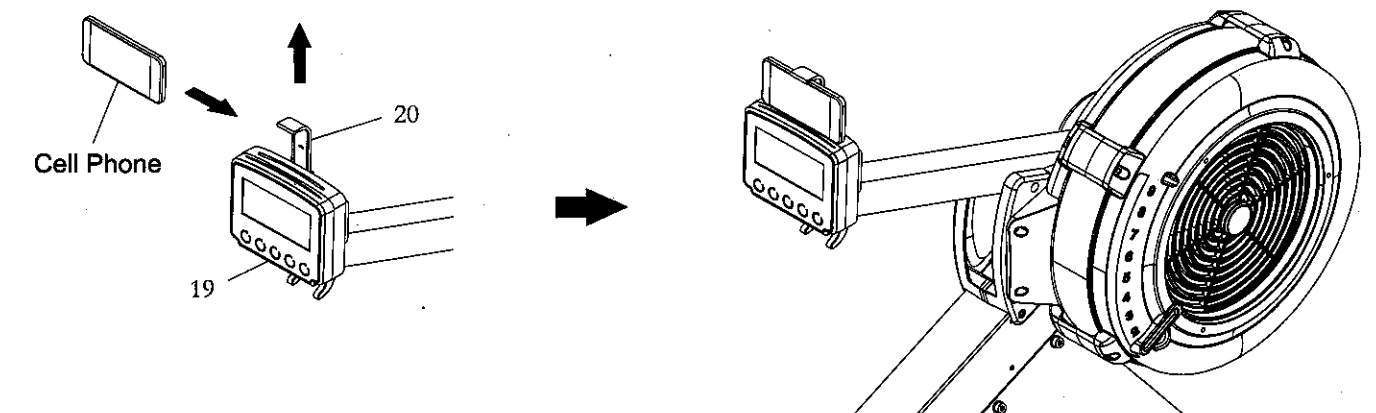

MAINTENANCE

The safety and integrity designed into the **ROWER** can only be maintained when the **ROWER** is regularly examined for damage and wear. Special attention should be given to the following:

1. Pull on the **Handlebar (3)** and verify that the Magnetic System provides tension and the seat travel is smooth and stable.
2. Clean the roller tracks in the **Stainless Steel Rail (14)** with an absorbent cloth.
3. Verify that all nuts and bolts are present and properly tightened. Replace missing nuts and bolts. Tighten loose nuts and bolts.
4. Check the condition of the **Chain (36)**. Replace the **Chain (36)** if it is cracked or broken.
5. Verify that the **Warning Label** is in place and easy to read.
6. It is the sole responsibility of the user/owner to ensure that regular maintenance is performed.
7. Worn or damaged components must be replaced immediately or the **ROWER** removed from service until repair is made.
8. Only Stamina Products supplied components should be used to maintain/repair the **ROWER**.
9. Keep your **ROWER** clean by wiping it off with an absorbent cloth after use.

MAINTENANCE

BUNGEE CORD ADJUSTMENT

Over time, about 250,000 strokes on **Handlebar (3)**, your **Bungee Cord (38)** may stretch. Follow the following process to adjust:

1. Position the **Main Frame Assembly (1)** as shown in the illustration. Remove the **Main Frame Top Cap (68)** from the **Main Frame (1)**. Slide out the **Bottom Cover (70)** from the **Main Frame (1)**.

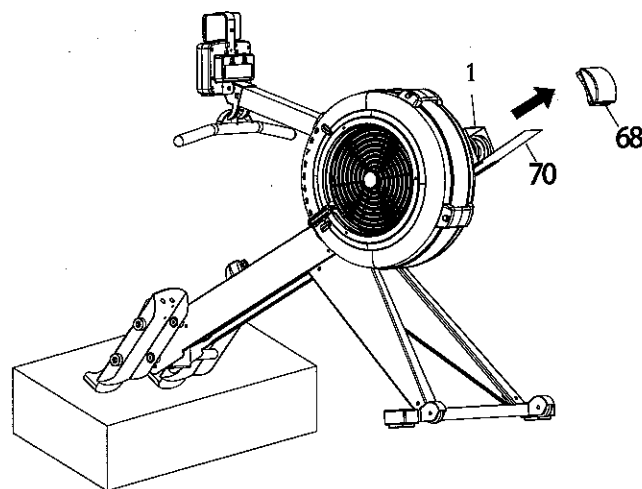

2. Position the **Main Frame Assembly (1)** as shown in the below illustration. Unhook the **Left Bungee Cord Hook (12L)** from the **Main Frame (1)**. Make a mark on the **Bungee Cord (38)** to move the hook forward 2 inches. Refer to **View 1** to **View 3** to untie the **Bungee Cord (38)** from the **Left Bungee Cord Hook (12L)**, and move the hook forward 2 inches. Refer to **View 4** to **View 6** to retie the **Bungee Cord (38)** to the **Left Bungee Cord Hook (12L)**. Hook the **Left Bungee Cord Hook (12L)** back into the **Main Frame (1)** and push the hook to the left side to touch the inner wall of the **Main Frame (1)**.

NOTE: Always use two hands with a secure grip when re-attaching the **Bungee Cord Hooks (12L & 12R)**.

Unhook the **Right Bungee Cord Hook (12R)** from the **Main Frame (1)**. Do the same as above to adjust the **Bungee Cord (38)** on the right side.

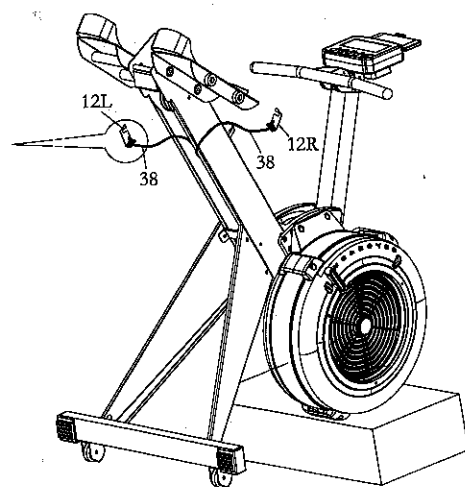
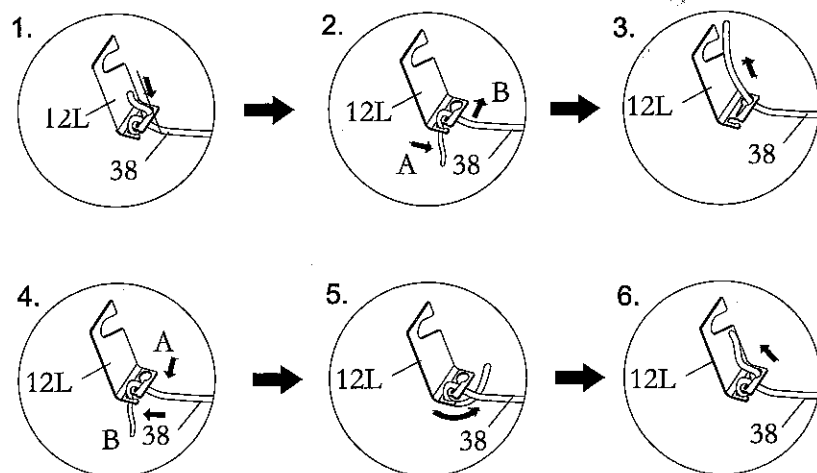

3. Position the **Main Frame Assembly (1)** as shown in the illustration. Slid the **Bottom Cover (70)** back into the **Main Frame (1)**. Press the **Main Frame Top Cap (68)** into the **Main Frame (1)**.

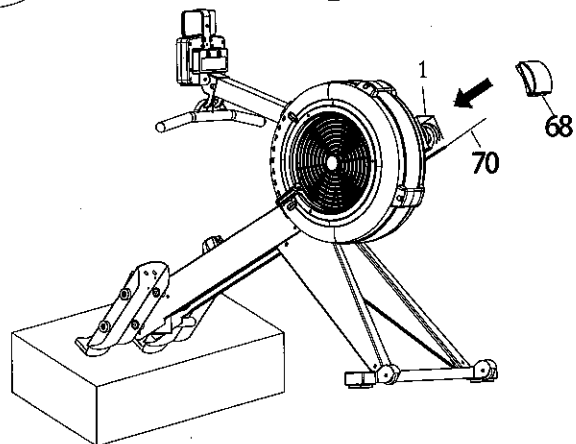

STORAGE

1. To store the **ROWER**, simply keep it in a clean dry place.
2. To avoid damage to the electronics, remove the batteries from the **Console Monitor (19)** before storing the **ROWER** for one year or more.
3. Move the **ROWER** with the **Transport Wheels (66)** on the **Front Stabilizer (4)**. Lift the **Rear Stand** of the **Rail Frame (2)** to move the **ROWER**. Refer to the illustration below. Do not use the **Seat (51)** to move the **ROWER**. The **Seat (51)** will move and the **Seat Carriage (10)** may pinch your hand or fingers.

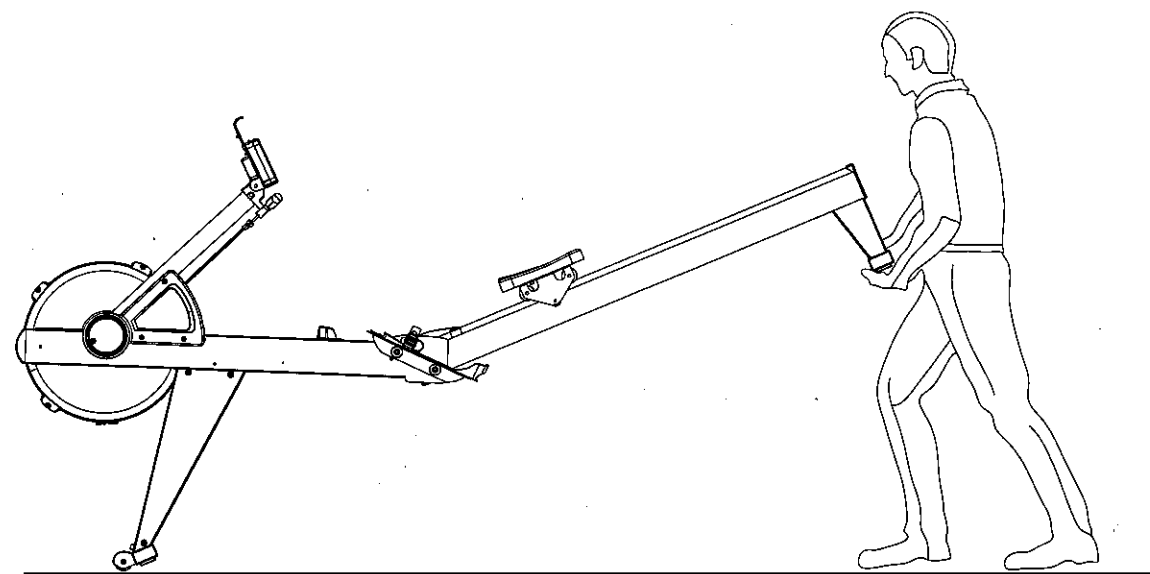

4. The **Main Frame (1)** and the **Rail Frame (2)** can be separated to minimize the unit size for storage. Remove the **Pull Pin (98)** from the **Main Frame (1)**. Lift up the **Main Frame (1)** and pull out the **Rail Frame (2)** to separate. Insert the **Pull Pin (98)** back to the hole in the **Main Frame (1)** for storage.

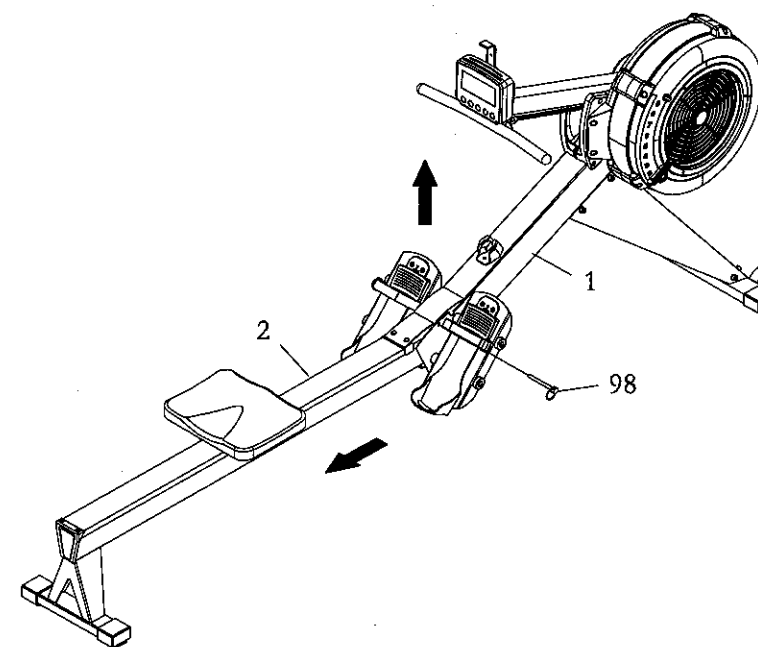

PRODUCT PARTS DRAWING

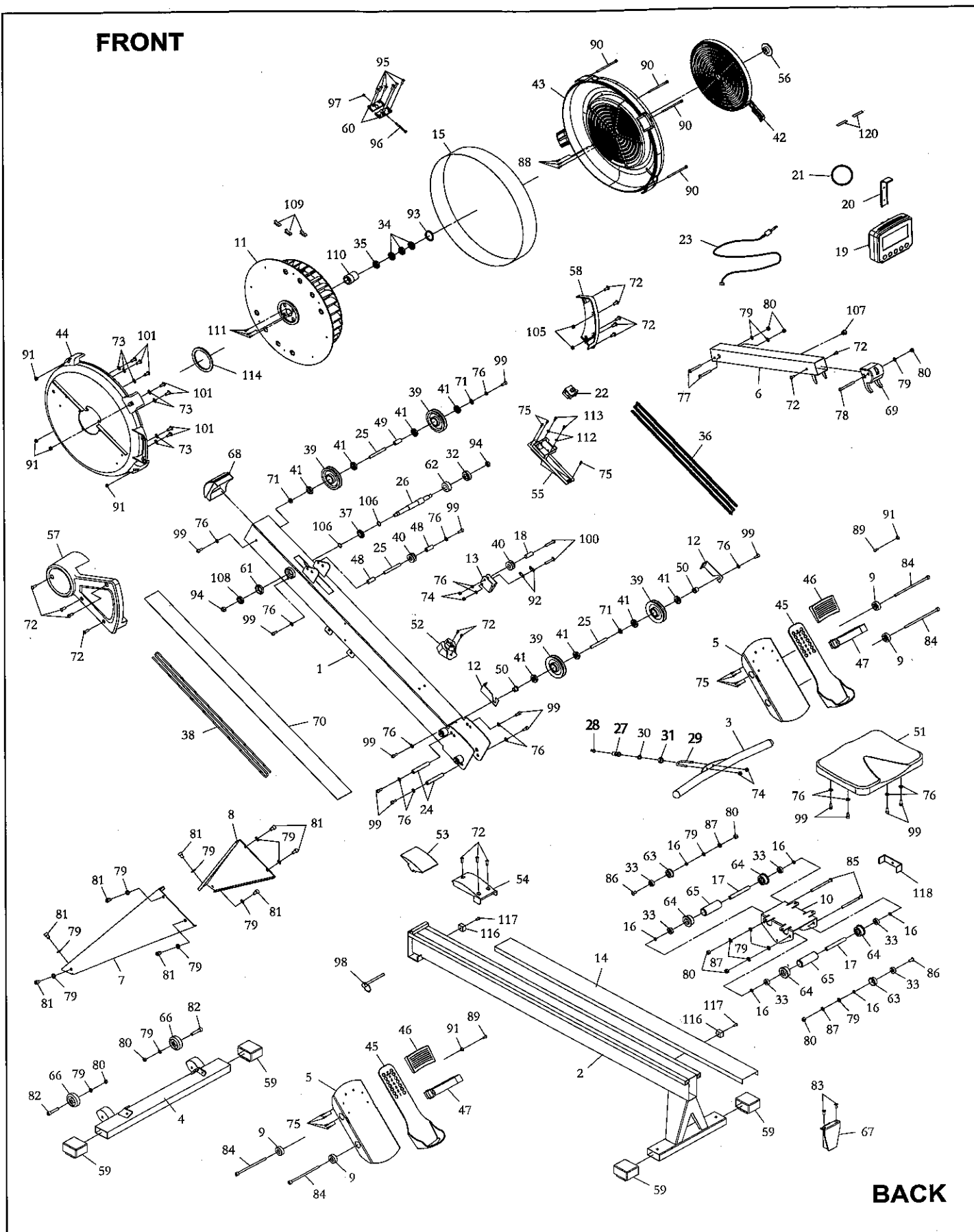

PARTS LIST

PART#	DESCRIPTION	QTY
1	Main Frame	1
2	Rail Frame	1
3	Handlebar	1
4	Front Stabilizer	1
5	Pedal Support Plate	2
6	Console Monitor Post	1
7	Left Support Leg	1
8	Right Support Leg	1
9	Foot Pedal End Cap	4
10	Seat Carriage	1
11	Fan	1
12	Bungee Cord Hook	2
13	Chain Bracket	1
14	Stainless Steel Rail	1
15	Perforated Steel Mesh	1
16	Spacer, $\varnothing 8.2 \times \varnothing 12 \times 3.2 \text{mm}$	6
17	Spacer, $\varnothing 8.2 \times \varnothing 12 \times 71.6 \text{mm}$	2
18	Spacer, $\varnothing 6.2 \times \varnothing 10 \times 15.5 \text{mm}$	1
19	Console Monitor	1
20	Cell Phone Bracket	1
21	Rubber Band	1
22	Generator	1
23	Sensor Cable	1
24	Shaft, M6x $\varnothing 12 \times 80 \text{mm}$	2
25	Shaft, M6x $\varnothing 10 \times 76.5 \text{mm}$	3
26	Fan Axle	1
27	Hook Connector	1
28	Chain Connector	1

29	U Bolt	1
30	Inner Spacer	1
31	Outer Collar	1
32	Bearing 6003RS	1
33	Bearing 608ZZ	6
34	Bearing 6201RS	3
35	One Way Bearing HF2016	1
36	Chain	1
37	Sprocket	1
38	Bungee Cord	1
39	Bungee Cord Pulley	4
40	Chain Roller	2
41	Bearing 6000ZZ	8
42	Damper	1
43	Right Fan Shroud	1
44	Left Fan Shroud	1
45	Foot Pedal	2
46	Foot Pedal Holder	2
47	Pedal Strap	2
48	Spacer, $\varnothing 10 \times \varnothing 16 \times 30.5 \text{mm}$	2
49	Pulley Spacer, $\varnothing 10 \times \varnothing 16 \times 26.5 \text{mm}$	1
50	Pulley Bushing	2
51	Seat	1
52	Handlebar Holder	1
53	Upper Joint Cover	1
54	Lower Joint Cover	1
55	Generator Base	1
56	Damper Cap	1
57	Left Side Cover	1
58	Right Side Cover	1
59	Foot Cap	4
60	Steel Plate	2

61	Bushing 6001	1
62	Bushing 6003	1
63	Guide Roller	2
64	Seat Roller	4
65	Roller Sleeve	2
66	Transport Wheel	2
67	Rail End Cap	1
68	Main Frame Top Cap	1
69	Console Mounting Bracket	1
70	Bottom Cover	1
71	Plastic Washer, $\varnothing 10.2 \times \varnothing 14 \times 1 \text{mm}$	3
72	Phillips Head Screw, M6x10mm	16
73	Lock Washer, Internal Tooth M6	7
74	Nylon Lock Nut, M6	4
75	Phillips Head Screw, ST4.2x10mm	11
76	Flat Washer, M6	16
77	Socket Head Cap Screw, M8x65mm	2
78	Button Head Cap Screw, M8x75mm	1
79	Flat Washer, M8	17
80	Nylon Lock Nut, M8	9
81	Socket Head Cap Screw, M8x12mm	8
82	Socket Head Cap Screw, M8x40mm	2
83	Phillips Flat Head Screw, M6x16mm	2
84	Socket Head Cap Screw, M8x160mm	4
85	Socket Head Cap Screw, M8x110mm	2
86	Button Head Cap Screw, M8x25mm	2
87	Lock Washer, M8	4
88	Phillips Head Screw, ST4.2x16mm	3
89	Phillips Head Screw, M5x8mm	2
90	Socket Head Cap Screw, M5x92mm	4
91	Hex Nut, M5	6
92	Chain Hook	2